

公司介绍

COMPANY PRESENTATION

中国·景德镇

Jingdezhen, China





汇报提纲 CONTENTS

PART

01

Enterprise Profile

PART

02

Products and R&D

PART

03

Advantageous Products Introduction



PART 1

公司简介 Enterprise Profile



一、公司概况 Enterprise Profile

Changhong Huayi was **founded in 1990**, headquartered in Jingdezhen, Jiangxi province, and it is the world's **largest household refrigerator and commercial compressor manufacturer**, with **six manufactural bases** all over the world.

cubigel[®] compressors Huayi Compressor Barcelona, S.L.



Headquarter **Jingdezhen**, Jiangxi





Mexico Branch Company

Jiaying, Zhejiang



Huayi Jingzhou, Hubei



Weile Automobile Air Conditioner Songjiang Shanghai



一、发展历程 Development History



1990年
华意成立
Established



1996年
江西省第二家
深交所上市
Went Public



2001年
建立荆州华意
Huayi(jingzhou) Factory



2007年
长虹入驻华意
Changhong Holding Huayi



2012年
收购Cubigel
Acquired HCB



2014年
建商用生产线
Commercial production line



2017年
制造业单项冠军
Champion in Manufacturing Industry



2019年
商用研发中心成立
R&D Center of commercial compressor founded

成为全球受尊敬的压缩机企业

Become a globally respected compressor company

1993年
年产100万
产线投产
Annual 1M Production line



2000年
国家火炬计划
高新技术企业
High-tech Company



2002年
并购控股
“加西贝拉”
Holding Jiaxipera



2009年
实现华意
整体搬迁 Move to new manufacture base



2013年
全球行业规模
第一
No.1 in compressor Industry



2016年
华意压缩机研究院
成立
Huayi Compressor Institute Established



2018年
全国商用第一
全球商用第二
Commercial rank No.1 in China and NO.2 in the world



2023年
建立墨西哥工厂
MEXICO BRANCH COMPANY ESTABLISHED



一、品牌布局 Brand layout

THE GROUP



jiaxipera

cubigel
compressors

CHANGHONG HUAYI COMPRESSOR CO. LTD

Leading compressor manufacturer. The company is held by Sichuan Changhong Electric Co. Ltd and has three subsidiaries:

- Jiaxipera Compressor Limited Company
- Huayi Compressor(Jingzhou) Co.,Ltd.
- Huayi Compressor Barcelona,S.L.
- Huayi Compressor mexico,s,L.

It operates with trademarks Huayi, Jiaxipera and Cubigel Compressors with annual sales of 80,0 MM units



Capacity of **90 Million** compressors



8.000 employees



7 factories worldwide
800.000 m²



Turnover **1.700 Million €**

CHANGHONG

SICHUAN CHANGHONG ELECTRIC CO., LTD

Established in 1958, Changhong is one of the largest consumer electronic products manufacturer in China

Changhong brand is the No.1 best selling of TV in Chinese market for last 17 years.



90,000 employees



Turnover **US\$ 20.000M**

一、年销量 Annual Sales



Cubigel light commercial compressors
world **No.1** since 2024

Huayi group refrigeration compressors
world **No.1** since 2013

Annual Sales(millions)

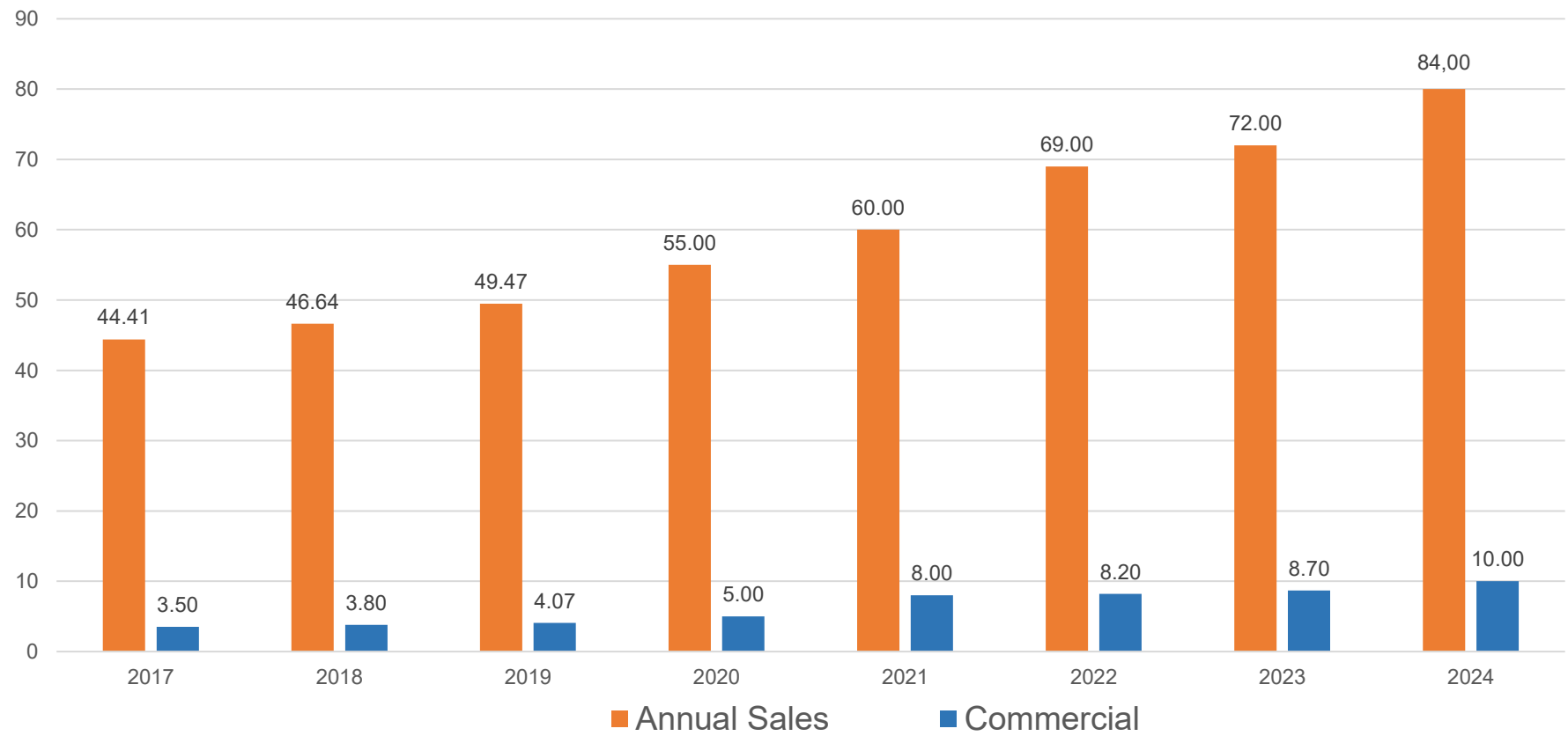

一、顾客和市场 Customers and Marketshare

Products have been supplied all over the world

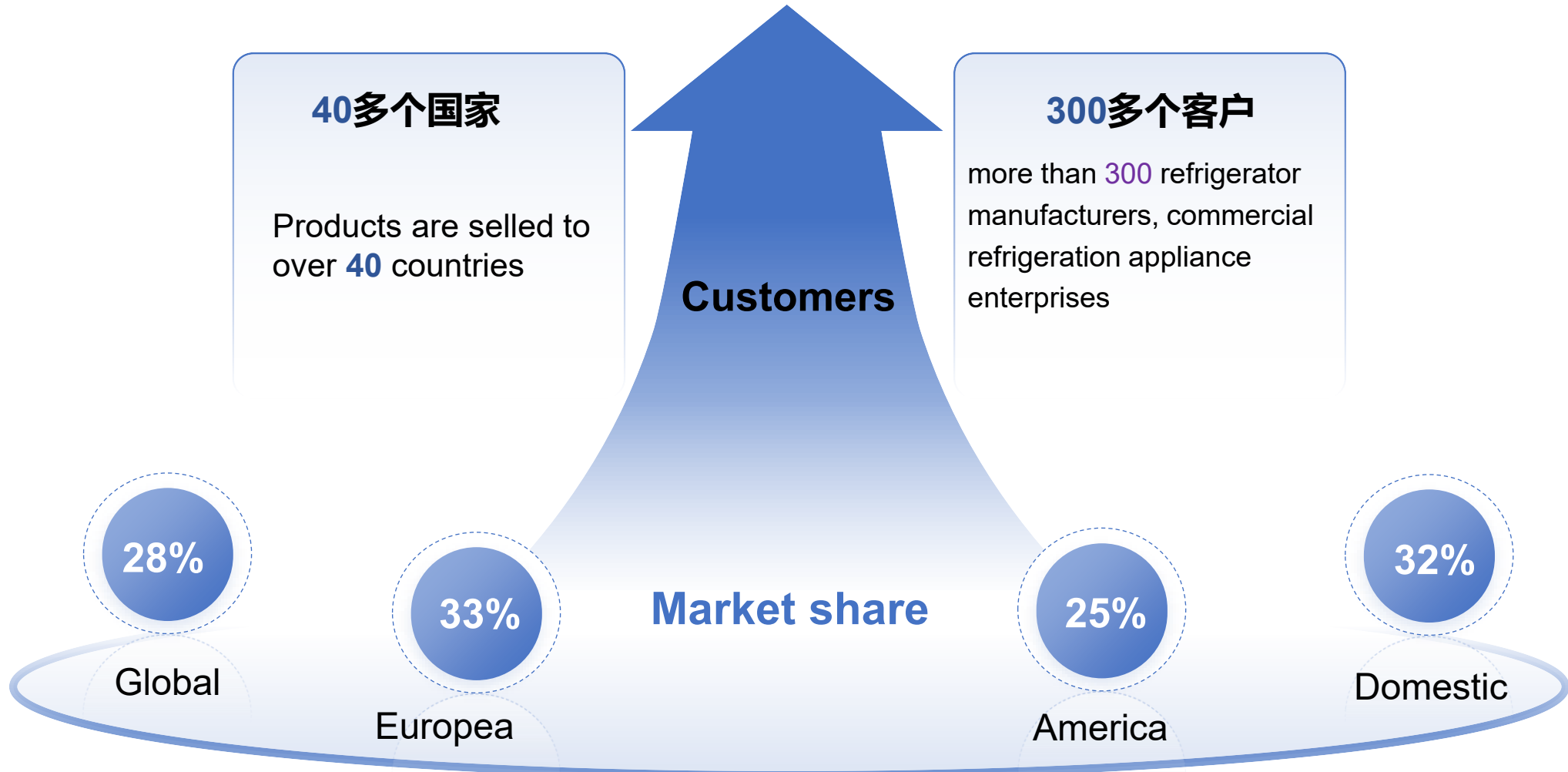

一、顾客和市场 Customers and marketshare

国内客户 DOMESTIC CUSTOMERS

Haier

Midea

美菱 Meiling

KINGHOME 晶弘冰箱

Hisense
创新就是生活
海信

TCL

KONKA
康佳

SKYWORTH
创维电器

AUCMA

Xing 星星

Homa 奥马

Hiron 海容

KEG
韩电集团

香雪海

新飞冰箱

银都餐饮设备
YINDU KITCHEN EQUIPMENT

Panasonic
松下冷链（大连）有限公司

Snowky 雪祺

Cornelius

LONSID

Dukers

ORIENT 澳润

MAGEX

华凌



一、顾客和市场 Customers and marketshare

国际客户 OVERSEAS CUSTOMERS

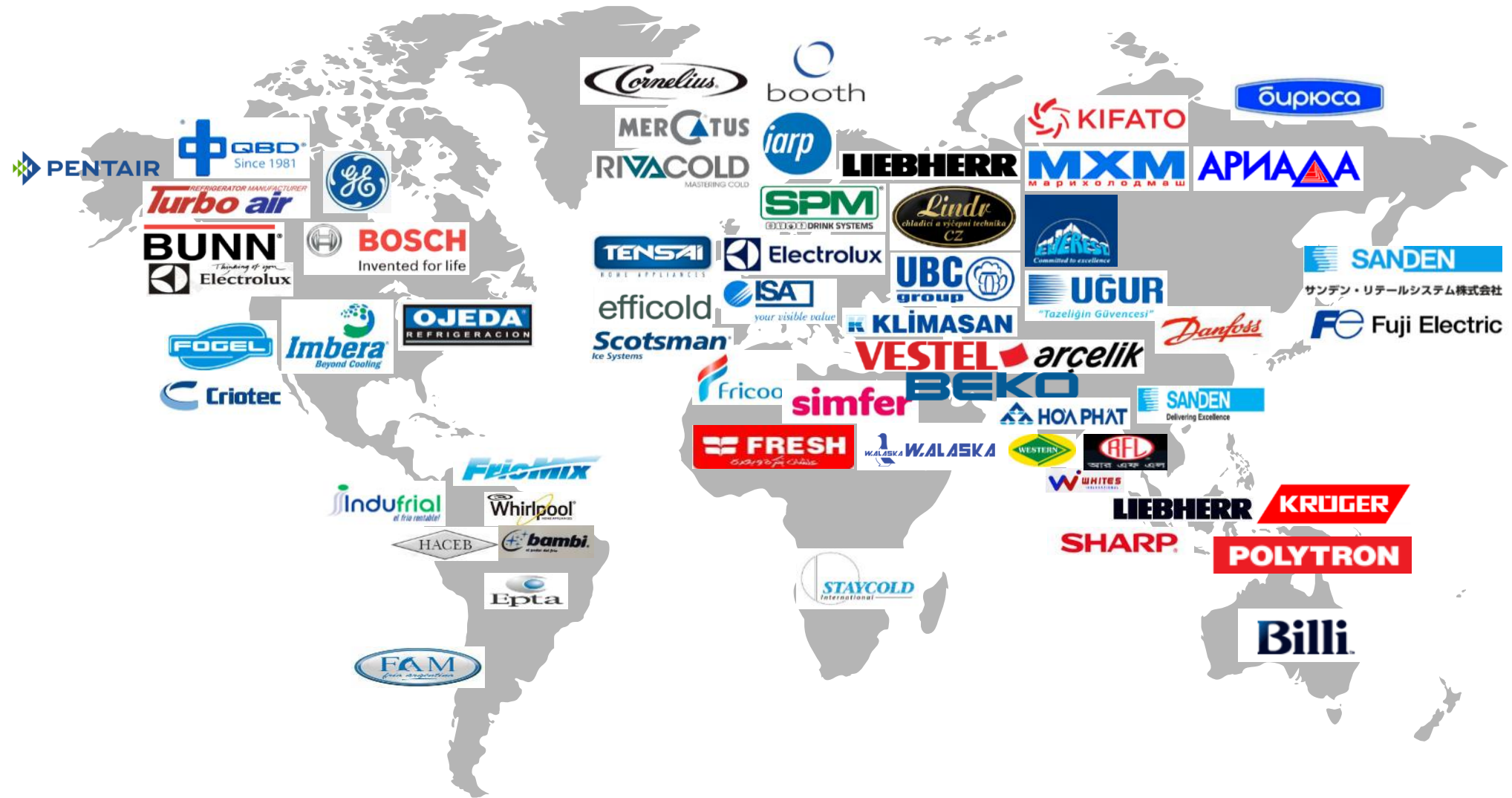



PART 2

产品与技术 Products and R&D

二、产品优势 Product Advantages

1 Refrigerant

R290、R134a
R404A、R600a,
R513a, R1234yf

2 Approvals

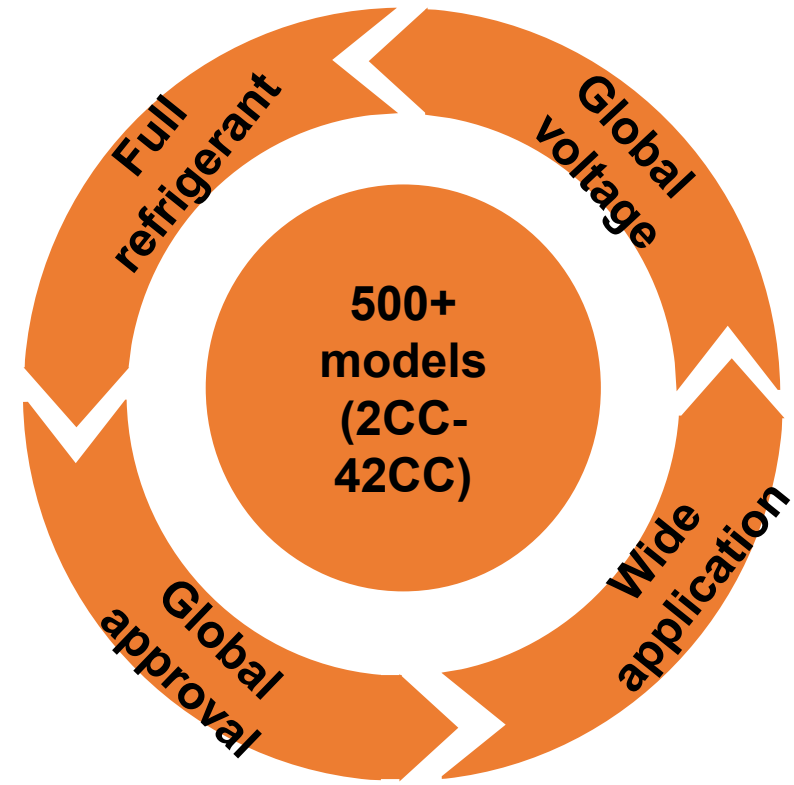
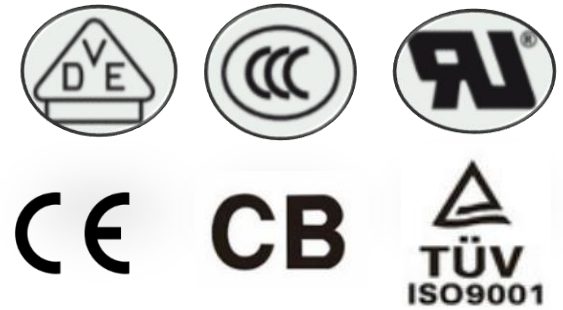

3 Adaptable voltage type

Domestic power supply
North American power supply
Southeast Asia power supply
South Korea power supply
Japanese power supply.....

4 Application range

Adaptable to LBP、LMBP、HBP、VHBP condition, in household and commercial application

二、专业能力 Professional ability

技术积累 technology accumulation



30+ years experience in household compressor development and manufacturing



60+ years experience in commercial compressor development and manufacturing

工作经验 technology accumulation

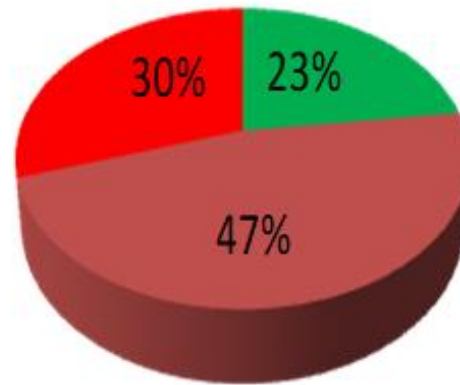

■ < 3 Years ■ 3-10 Years ■ > 10 Years

技术团队 technical team

366 技术专家
Professional Experts

80 核心成员
Core members

12 博士专家
Doctors Experts

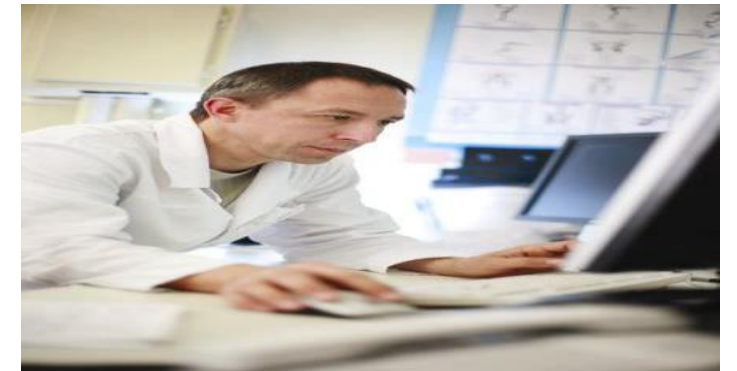

- With rich industry experience and a professional technical team, we can deeply understand the business needs and market pain points of our clients, and provide innovative solutions to help customers enhance their product competitiveness and market share.
- Offer differentiated product designs (such as low-noise and ultra-low-temperature compressors), meet diverse scenarios' demands, and customize products with distinct features based on customers' specific needs to meet the special requirements in different application scenarios.

二、服务团队 Service team

- A specialized service team for the entire product life cycle



Provide customers with comprehensive technical support, starting from the design and development stage of the products, assisting them in optimizing the product design and ensuring the reliability, stability and compatibility of the products.

We can offer customers more favorable prices and supply guarantees, while also deeply understanding their needs and pain points, and continuously optimizing the service processes and systems to provide customers with more personalized and professional services, thereby establishing long-term and stable cooperative relationships.

During the production and use of the product, provide after-sales service and quality monitoring, quickly solve the product problems encountered by customers, and ensure that the product meets the quality requirements and standards of the customers.

二、推广策略 Promotion strategy

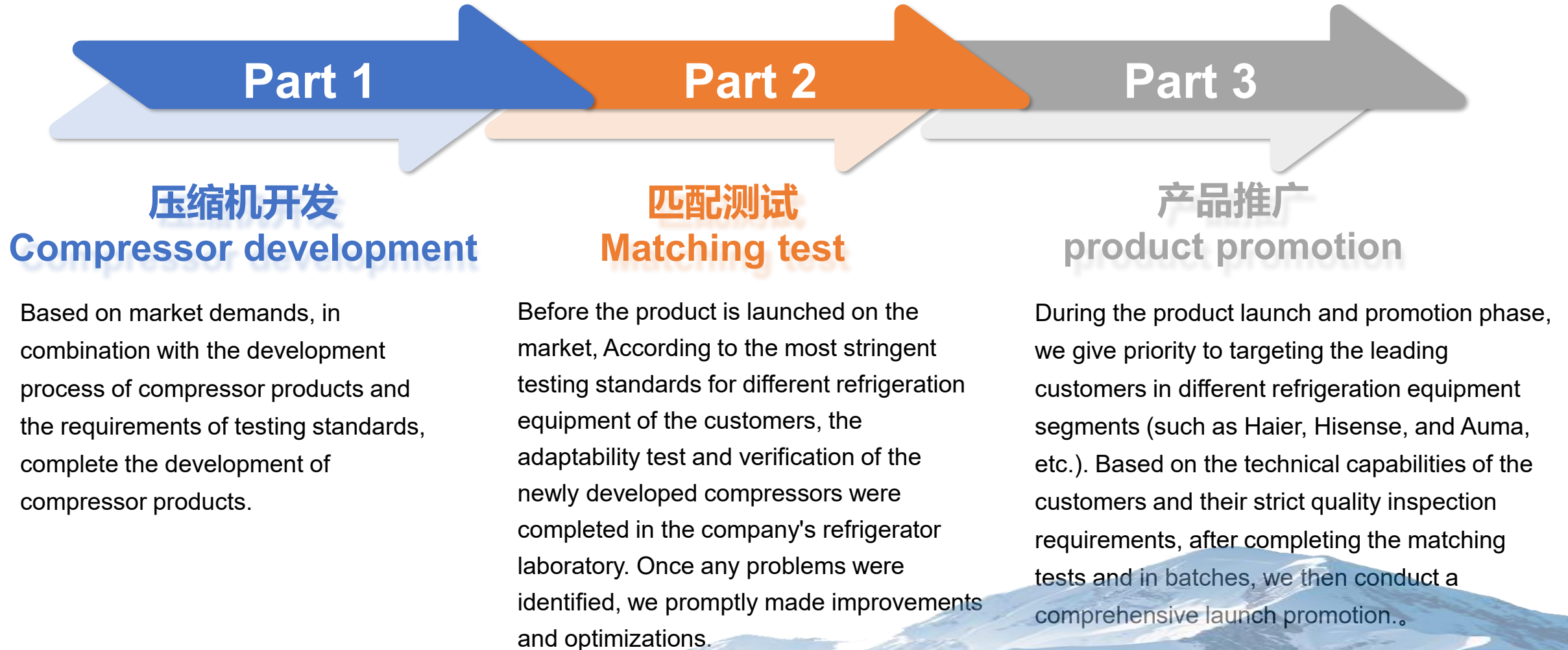

二、可靠性验证 Reliability test

Product reliability verification

压缩机 Compressor

- Cooling performance test
- Noise and vibration test
- Drop and rolling test
- Starting performance test
- Power-off reset experiment
- Oil discharge volume test
- High-temperature life test
- Winding temperature test
- Piston lock test
- Start-stop shell impact test
- ...

变频控制板 PCB board

- Rotational speed performance test
- Acceleration and deceleration test
- Protection performance test
- Balance pressure and differential pressure startup test
- Safety performance test
- EMC testing
- ...

主要配件 Main components

- Non-metallic component high-temperature compatibility test
- Motor, silicon steel sheet, enameled wire high-temperature compatibility test
- Complete machine salt spray test
- Freezing oil life test
- Capacitor 1000-hour life test
- PTC starter 200,000 times start-stop test
- ...

Total: More than 50 tests have fully verified the reliability of the compressor.



二、核心技术 Core technology

Core technology innovation of Huayi Group 核心技术创新:

Structural dynamics
机械学科

Friction lubrication
摩擦学科

Heat flow coupling
流体学科

Acoustic vibration
声学学科

Motor control
电机学科

Electronic control
电控学科

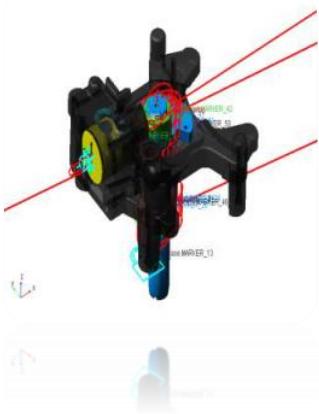

deformation make up technologies
变形补偿技术

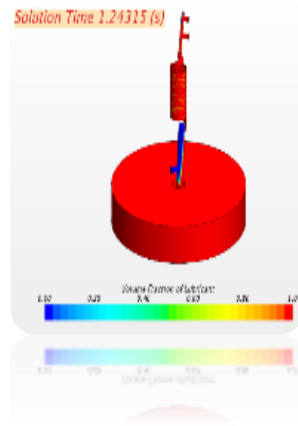

Production validation test technologies
PV测试技术

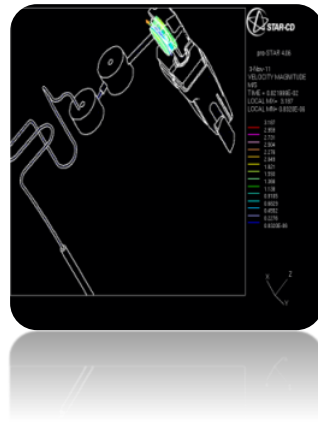

10 years life cycle reliabilities technologies
10年高可靠性技术



acoustic identification and noise reduction technologies
声源识别、低噪声技术

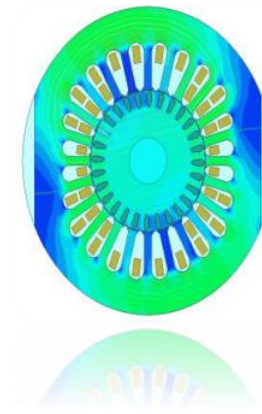

High efficiency motor technology
高效电机技术

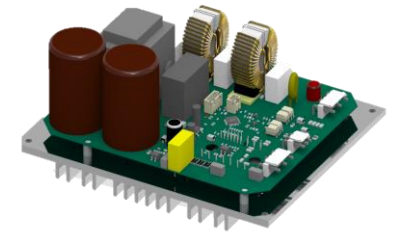

AI control self-adaptive algorithm
智能控制、底层算法

二、实验中心 Laboratory Center

Industry leading laboratory resources: **CNAS** national accredited laboratories, **UL** and **VDE** accredited laboratories that comply with **TAP** and **TDAP** procedures. Provide strong guarantee for R&D and quality control.

行业领先的实验资源: CNAS国家认可实验室, 符合TAP和TDAP程序的UL和VDE认可实验室。为技术研发和质量控制提供有力保障。

9 professional laboratories:

Materials Laboratory, Fluid mechanics Laboratory, Thermodynamics Laboratory, abrasion and lubrication Laboratory, Chemistry Laboratory, Precision Laboratory, Acoustics Laboratory, EMC Laboratory, Motor and electrical Control Laboratory

6 compressor laboratories:

Compressor performance laboratory, compressor noise laboratory, compressor overload laboratory, compressor blocking rotation laboratory, compressor startup laboratory, application matching laboratory

6 reliability laboratories:

Compressor reliability laboratory, PCB reliability laboratory, capacitor reliability laboratory, electrical parts reliability laboratory, valve system reliability laboratory, transportation reliability laboratory.



二、实验中心 Laboratory Center



性能实验室 Performance Lab



Noise Lab
噪声实验室



Reliability lab
寿命实验室



Overload Lab
过载实验室



Winding Lab
绕组实验室



Matching Application Lab
匹配应用实验室

二、实验中心 Laboratory Center



材料实验室

Materials laboratory

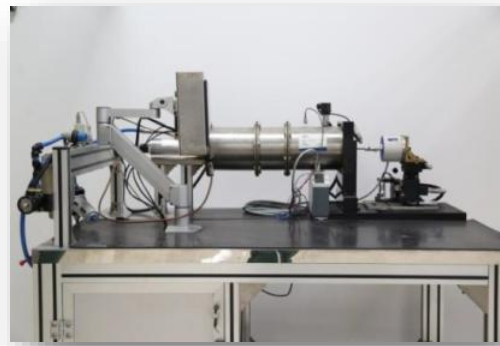

流体实验室

Fluid Laboratory



热力学实验室

Thermodynamic laboratory

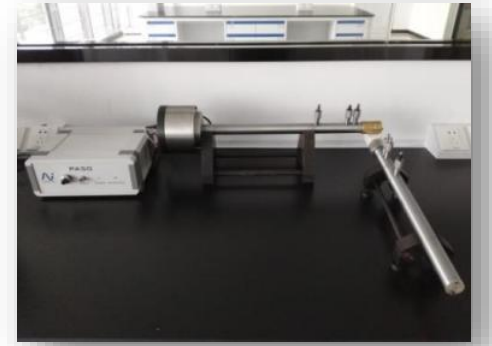

声学实验室

Acoustical Laboratory



EMC实验室

EMC Laboratory



磨擦与润滑实验室

Friction and Lubrication Laboratory



化学实验室

Chemistry Laboratory

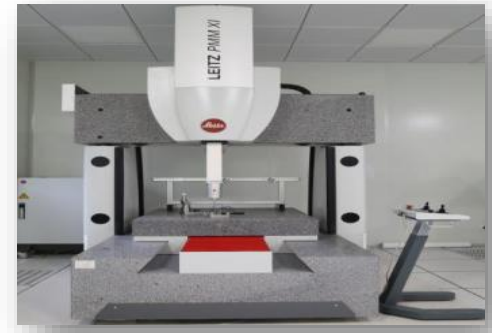

精密实验室

Precision laboratory



PART 3

优势产品介绍 Advantageous Products Introduction

01

HVX series new generation products



1、HVX系列新一代产品 HVX series new generation products

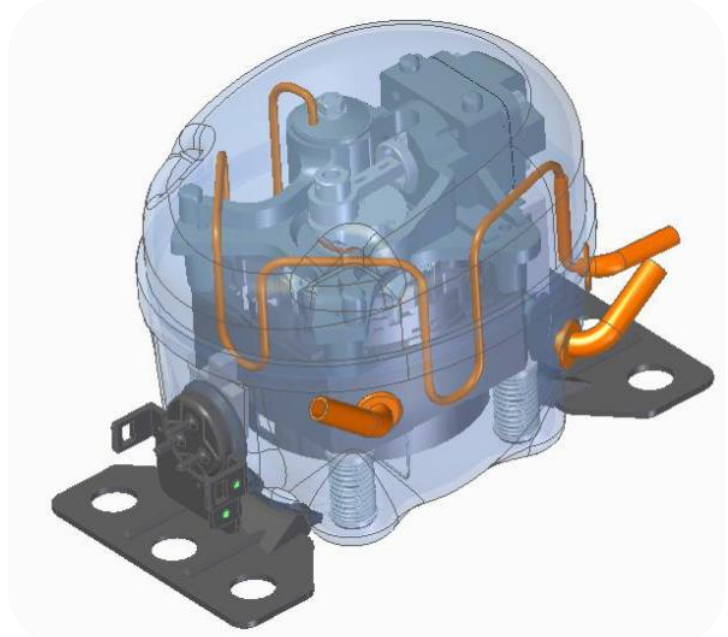

- 外形尺寸External dimensions: 151*128*127
- 整机重量Compressor weight: 3.5-3.8kg
- 驱动器整体式安装, 适用压缩机仓紧凑场景; 完全符合新欧标标准;
- 应用场景Application scenarios: 冰箱、冷柜、展示柜

小型化 Compact design

增加整机适用容积、性价比提升.

低噪声 Low noise

高模态壳体、低噪声消音器及排气串联结构.

高效化 High efficiency

采用高效机械运动部件、高效阀组系统, 防排油设计提升系统效率.

宽运用 Wide application

全球电源制式

高可靠性 High reliability

四脚支撑结构、产品稳定性、一致性好

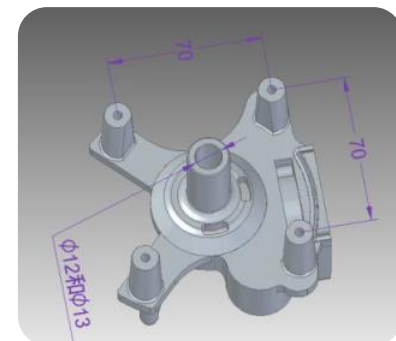

3、HVX系列新一代产品 HVX series new generation products

◆ 产品阵列 Product array

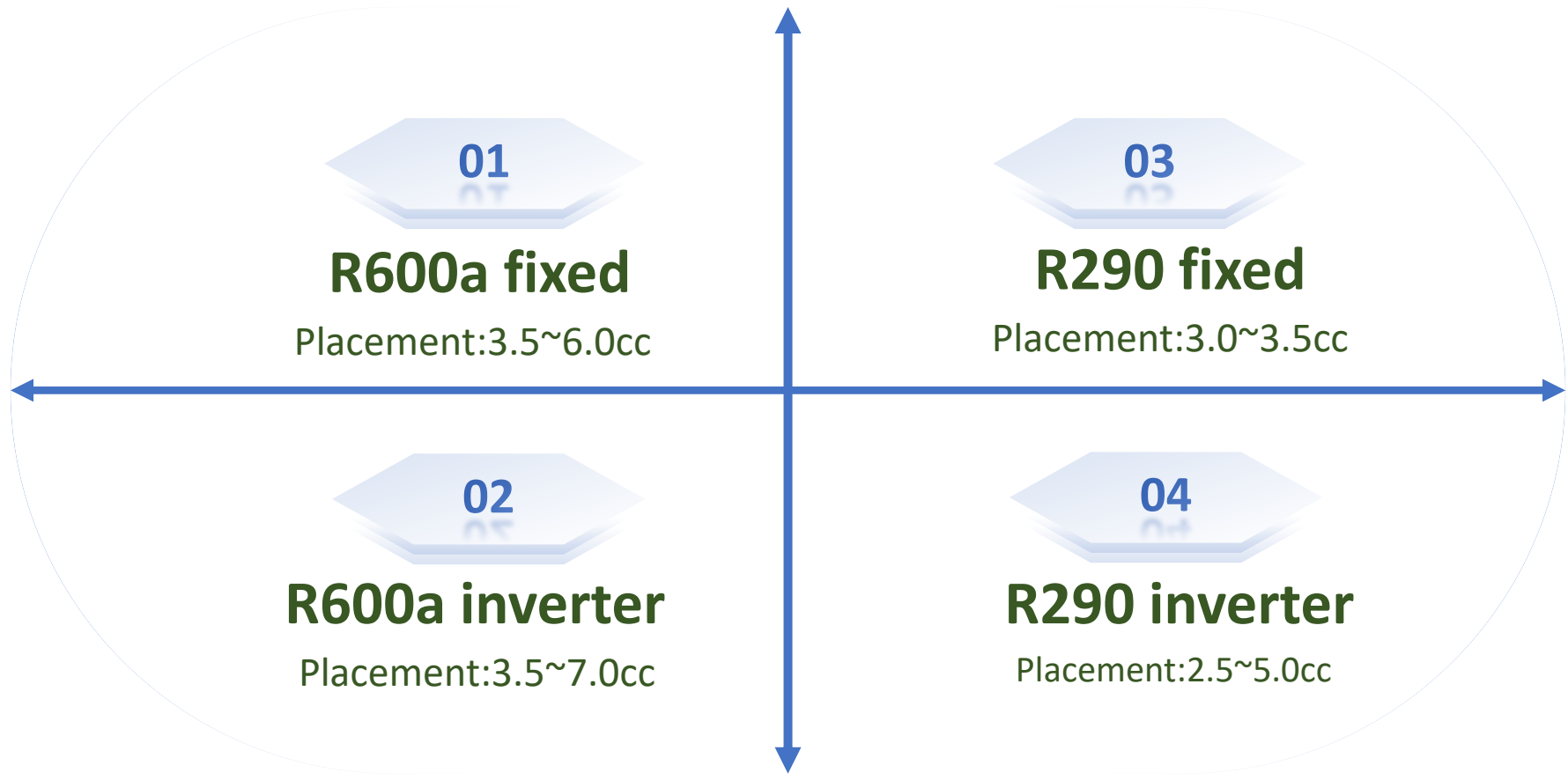

Household noise, commercial quality

1、HVX系列新一代产品 HVX series new generation products

家用噪声 (超静音) Household noise (ultra-quiet)

商用定频产品
NXC30/35CA

R290噪声 (Noise) : 33dB

波动: 3dB (A)

家用定频产品
HYX50/60MA

R600a噪声 (Noise) : 32dB

波动: 3dB (A)

VS

行业水平 Industry noise level

30/35排量

R290噪声: 41dB

波动: 8dB (A)

8排量

R600a噪声: 35dB

波动: 5dB (A)

9-10排量

R600a噪声: 37dB

波动: 6dB (A)

对比商用
Commercial
comparison



7-8dB

对比家用
Household
comparison



2-3dB

1、HVX系列新一代产品 HVX series new generation products

➤ NX/NB系列R290商用市场应用概况 Market Application Overview of NX/NB series R290 compressor :

<p>01. 项目匹配 Project matching</p> <p>完成52个客户推进新品项目匹配共113项 Total finished 113 items of new project matching from 52 clites</p>	<p>02. 应用范围 scope of application</p> <p>饮料展示柜、厨房柜、普通冷柜、冰淇淋柜、蛋糕柜等 Bottler Cooler, Kitchen Cabinet, Chest Freezer, Ice Cream Cabinet, Cake Cabinet, etc.</p>	<p>03. 市场用量 market Usage</p> <p>截至2024年, 已形成市场使用100万台以上, 市场表现稳定 More than 1 million units have been developed for market use by 10/2024, with stable market performance</p>
--	--	---

➤ 典型产品应用 Typical product application:



<p>主要客户 Main clients</p>	<p>海尔、美菱、美的 Haier, Meiling, Midea</p>	<p>星星、海容、澳柯玛 xingxing, Hairo, Aucma</p>	<p>海尔、海信、海容、澳柯玛 Haier, Hisense, Hiron, Aucma, Everest</p>	<p>星星、凯利、渠道 xingxing, Unuo, Chanel</p>
<p>批量型号 mass produced models</p>	<p>NXC30CA、NXC35CA NBC40NA、NBC45NA、</p>	<p>NXC35CA、NBC45NA、 NBC40NA、NBC35NC</p>	<p>NXK35FSC、NXG50FSC NXC35CA、NBC40NA NBC45NA、NBC45MK</p>	<p>NXC35CA NBC45NA</p>
<p>被替代型号 replaced models</p>	<p>HYB81MHUa、 HYB96MHUa S118CY1、HYS113MCA</p>	<p>HYB81MHUa、 HYB96MHUa HYE125MHU</p>	<p>HYB90MHUa、 HYB96MHUa L118CY1、SZ90EIJ</p>	<p>HYB81MHUa HYS113MCA S118CY1</p>

1、HVX系列新一代产品 HVX series new generation products

◆ HVX系列新一代产品 ---R600a Compressor

类别 Type	压缩机型号 Model	工质 Refrigerant	工况 Application	冷量(W) capacity	COP	噪声 noise	电源制式 V/Hz
Fixed	HYX35MA	R600a	LBP	55	1.2	39	220-240V~50Hz
	HYX40MCK	R600a	LBP	65	1.15	40	160-260V~50Hz
	HYX50MCK	R600a	LBP	78	1.15	40	160-260V~50Hz
	HYX60MA	R600a	LBP	95	1.2	39	220-240V~50Hz

类别 Type	压缩机型号 Model	工质 Refrigerant	工况 Application	冷量(W) capacity	COP	噪声 noise	转速rpm
Inverter	HVX35MK	R600a	LBP	80	1.6	39	1320-4320
	HVX50MK	R600a	LBP	120	1.6	39	1320-4320
	HVX60MK	R600a	LBP	140	1.6	39	1320-4320
	HVX60MT	R600a	LBP	140	1.75	39	1320-4320
	HVX70MK	R600a	LBP	160	1.6	39	1320-4320
	HVX70MT	R600a	LBP	160	1.75	39	1320-4320

应用场景

Application case



≤300L



≤350L

1、HVX系列新一代产品 HVX series new generation products

◆ HVX系列新一代产品 ---R290 Compressor

类别 Type	压缩机型号 Model	工质 Refrigerant	工况 Application	冷量(W) capacity	COP	噪声 noise	电源制式 V/Hz
Fixed	NXC30CA	R290	LBP	130	1.2	43	220-240V~50Hz
	NXC30RA	R290	HBP	415	2.35	43	220-240V~50Hz
	NXC35CA	R290	LBP	145	1.2	43	220-240V~50Hz
	NXC30CR	R290	LBP	160	1.2	44	115-127V~60HZ

工质 Refrigerant	压缩机型号 Model	工质 Refrigerant	工况 Application	冷量(W) capacity	COP	噪声 noise	转速rpm
Inverter	NXK25FSC	R290	LBP	160	1.6	46	1600-4500
	NXK35FSC	R290	LBP	230	1.6	46	1600-4500
	NXG50FSC	R290	LBP	350	1.5	46	1600-4500
	NXK50FSC	R290	LBP	350	1.6	46	1600-4500

应用场景

Application case



02

R290 series commercial products

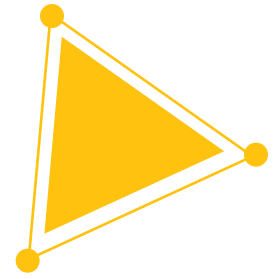

2、R290系列产品 R290 series commercial products

R290 Fixed compressors



平台 platform	X2	P2	N4	U	F	NB	NX
排量 Displacement(CC)	21-28	14-18	12-14	3.5-14	2.5-8	2.5-4.5	3.0-3.5
制冷量Capacity(w)	900-1200	820-1050	500-850	230-490	170-400	150-220	130-160
COP(w/w)	1.40-1.65	1.40-1.65	1.50-1.75	1.40-1.90	1.45-1.75	1.2-1.4	1.10-1.30
重量Weight(kg)	16-18	12-13.5	10.5-11	3.5-10.2	6.5-6.9	5.1-5.6	4.7-4.9
应用工况	LBP/LMBP HBP/HMBP	LBP/LMBP HBP/HMBP	LBP/LMBP HBP/HMBP	LBP/LMBP HBP/HMBP	LBP/LMBP HBP/HMBP	LBP/LMBP	LBP/LMBP HMBP

2、R290系列产品 R290 series commercial products

High Efficiency Compressor for EU New Energy label and Coca Cola upgrade

● Parameters of R290 compressor for beverage cooler and showcase

No.	Model	Application	Motor type	Cooling capacity/w	COP	Voltage/Hz
1	NFS30NA	LMBP	RSCR	150	1.80	220-240V 50Hz
2	NFS35NA	LMBP	RSCR	170	1.80	220-240V 50Hz
3	NFS40NA	LMBP	RSCR	200	1.80	220-240V 50Hz
4	NUS45NA	LMBP	RSCR	210	1.85	220-240V 50Hz
5	NUS55NA	LMBP	RSCR	265	1.85	220-240V 50Hz
6	NUS60NA	LMBP	RSCR	295	1.85	220-240V 50Hz
7	NUS70NA	LMBP	RSCR	330	1.85	220-240V 50Hz
8	NUS80NA	LMBP	CSR/RSCR	400	1.85	220-240V 50Hz
9	NUS90NA	LMBP	CSR/RSCR	440	1.85	220-240V 50Hz
10	NUS100NA	LMBP	CSR/RSCR	480	1.85	220-240V 50Hz
11	NUS120NA	LMBP	CSR/RSCR	580	1.85	220-240V 50Hz
12	NUS140NA	LMBP	CSR/RSCR	680	1.85	220-240V 50Hz
13	NUD45NA	LMBP	RSCR	210	1.90	220-240V 50Hz
14	NUD55NA	LMBP	RSCR	265	1.90	220-240V 50Hz
15	NUD60NA	LMBP	RSCR	295	1.90	220-240V 50Hz
16	NUD70NA	LMBP	RSCR	330	1.90	220-240V 50Hz
17	NUD80NA	LMBP	CSR/RSCR	400	1.90	220-240V 50Hz

- High efficiency and low noise
- Stable 、 reliable quality , and massive produced.
- widely used in beverage cabinets and ice cream conservator

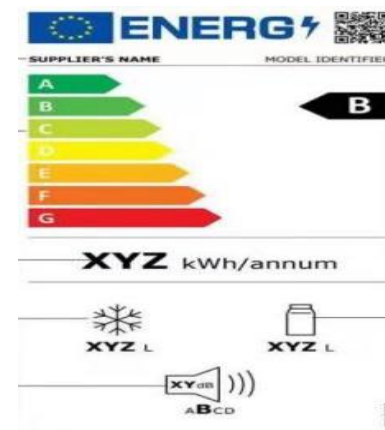

2、R290系列产品 R290 series commercial products

High Efficiency Compressor for DOE New Energy Label

● 115-127V/60Hz Parameters of R290 compressor

No.	Model	Application	Motor type	Cooling capacity/w	COP	Voltage/Hz
1	NFS25NR	LMBP	RSCR	150	1.80	115-127V/60Hz
2	NFS30NR	LMBP	RSCR	180	1.80	115-127V/60Hz
3	NFS35NR	LMBP	RSCR	200	1.80	115-127V/60Hz
4	NFT35NR	LMBP	RSCR	195	1.7	115-127V/60Hz
5	NFT45NR	LMBP	RSCR	265	1.7	115-127V/60Hz
6	NFT55NR	LMBP	RSCR	300	1.7	115-127V/60Hz
7	NFT60NR	LMBP	RSCR	380	1.7	115-127V/60Hz
8	NFT70NR	LMBP	RSCR	415	1.7	115-127V/60Hz
9	NUS45NR	LMBP	RSCR	265	1.80	115-127V/60Hz
10	NUS55NR	LMBP	RSCR	300	1.80	115-127V/60Hz
11	NUS60NR	LMBP	RSCR	380	1.80	115-127V/60Hz
12	NUS70NR	LMBP	RSCR	415	1.80	115-127V/60Hz
13	NUS80NR	LMBP	RSCR	490	1.80	115-127V/60Hz
14	NUS100NR	LMBP	CSR	600	1.80	115-127V/60Hz
15	NUT120NR	LMBP	CSR	710	1.70	115-127V/60Hz
16	NUT140NR	LMBP	CSR	810	1.70	115-127V/60Hz
17	NXH210NR	LMBP	CSR	1020	1.38	115-127V/60Hz
18	NXH230NR	LMBP	CSR	1180	1.38	115-127V/60Hz

- High efficiency and low noise
- Stable 、 reliable quality , and massive produced.
- widely used in beverage cabinets and ice cream conservator



2、R290系列产品 R290 series commercial products

Bound for India, Indonesia, Iraq and other wide voltage markets

Model	Displacement CC	Working condition	Cooling tyoe	Vol/Frequency	Motor	ASHARE(-23.3/54.4)		applied cabinets
						COOLING/ W	COP W/W	
NBC35NK	3.5	LMBP	ST/F	160-260V~50Hz	RSIR	150	1.30	Deep freeze, Botter cooler, ice cream conservator, Ice machine, Kitchen refrigerator, Supermarket Range
NBC40NK	4.0	LMBP	ST/F	160-260V~50Hz	RSCR	180	1.40	
NBC45NK	4.5	LMBP	ST/F	160-260V~50Hz	RSCR	210	1.40	
NSG45NA	4.5	LBP	ST/F	160-260V~50Hz	RSCR	220	1.55	
NFG60NK	6.0	LMBP	F	160-260V~50Hz	RSCR	295	1.5	
NFG70NK	6.7	LMBP	F	160-260V~50Hz	RSCR	330	1.5	
NUG80NK	8.1	LMBP	F	160-260V~50Hz	RSCR	390	1.55	
NUM90NA	9.0	LMBP	F	160-260V~50Hz	CSR	430	1.55	
NUG100NK	9.8	LMBP	F	160-260V~50Hz	CSR	480	1.55	
NUK120NK	12.5	LMBP	F	160-260V~50Hz	CSR	590	1.55	
NUK140NK	14.2	LMBP	F	160-260V~50Hz	CSR	680	1.55	
NXH260NK	26.0	LMBP	F	160-260V~50Hz	CSR	1150	1.55	

2、R290系列产品与应用 R290 Products and Applications

Bound for Korean、Saudi Arabia、Philippines market

Model	Voltage	Application	Motor type	Cooling capacity/w	COP
NFT40NG	200-220V~50Hz 230V 60Hz	LMBP	RSCR	200/240	1.65/1.75
NFT45NG	200-220V~50Hz 230V 60Hz	LMBP	RSCR	220/265	1.6/1.7
NUS45NG	200-220V~50Hz 230V 60Hz	LMBP	RSCR	230 / 270	1,78 / 1,83
NUS55NG	200-220V~50Hz 230V 60Hz	LMBP	RSCR	260/ 320	1,78 / 1,83
NUS60NG	200-220V~50Hz 230V 60Hz	LMBP	RSCR	300 / 360	1,78 / 1,83
NUS70NG	200-220V~50Hz 230V 60Hz	LMBP	CSCR	330 / 410	1,78 / 1,83
NUS80NG	200-220V~50Hz 230V 60Hz	LMBP	CSCR	400 / 480	1,75 / 1,80
NFH45NG	200-220V~50Hz 230V 60Hz	LMBP	RSIR	210	1.35
NFH60NG	200-220V~50Hz 230V 60Hz	LMBP	RSCR	295	1.35
NFH70NG	200-220V~50Hz 230V 60Hz	LMBP	RSCR	325	1.35
NUC45NG	200-220V~50Hz 230V 60Hz	LMBP	RSIR	210	1.35
NUC55NG	200-220V~50Hz 230V 60Hz	LMBP	RSIR	265	1.35
NUY60NG	200-220V~50Hz 230V 60Hz	LMBP	CSR	295	1.55
NUC70NG	200-220V~50Hz 230V 60Hz	LMBP	CSIR	325	1.35
NUY80NG	200-220V~50Hz 230V 60Hz	LMBP	CSR	390	1.55
NUY90NG	200-220V~50Hz 230V 60Hz	LMBP	CSR	430	1.55
NUY100NG	200-220V~50Hz 230V 60Hz	LMBP	CSR	470	1.55
NUH120NU	220-240V~60Hz	LMBP	CSR	670	1.50
NPY14NU	220-240V~60Hz	LMBP	CSR	800	1.45
NXH260NG	220-240V~50/60Hz	LMBP	CSR	1150/1340	1.35/1.42
NXH260NG	220-240V~50/60Hz	LMBP	CSR	1220/1390	1.3/1.4

2、R290系列产品 R290 series commercial products

Compressor for Supermarket Island Freezer and Cooler



Model	Refrigerant	Voltage/Frequency	Application	Cooling capacity	COP
NUK120NA	R290	220-240V 50Hz	LMBP	580	1.6
NUK140NA	R290	220-240V 50Hz	LMBP	660	1.6
NUT120NR	R290	115-127V 60Hz	LMBP	670	1.6
NUT140NR	R290	115-127V 60Hz	LMBP	770	1.6
NPY12RR	R290	115-127V~60Hz	HMBP	1860	2.68
NPY14NU	R290	220-240V~60Hz	LMBP	797	1.50
NPY16NC	R290	100V~50/60Hz	LMBP	810 (50Hz)	1.38
NPY14NA	R290	220-240V/50Hz	LMBP	650	1.45
NPY16NA	R290	220-240V/50Hz	LMBP	760	1.45
NPY18NA	R290	220-240V/50Hz	LMBP	820	1.40
NPY18LR	R290	115-127V/60Hz	LBP	950	1.4
NPK16NA	R290	220-240V/50Hz	LMBP	760	1.65

2、R290系列产品 R290 series commercial products

Compressor for Air curtains and Supermarket freezer



Model	Application	Refrigerant	Voltage/Frequency	Cooling capacity	COP
NXH210NA	LMBP	R290	220-240V~50Hz	880	1.4
NXH230NA	LMBP	R290	220-240V~50Hz	960	1.4
NXK230NA	LMBP	R290	220-240V~50Hz	1020	1.6
NXH260NA	LMBP	R290	220-240V~50Hz	1100	1.4
NXH210NR	LMBP	R290	115-127V/60Hz	1020	1.38
NXH210NG	LMBP	R290	220-240V~50/60Hz	880/1020	1.3/1.4
NXH230NG	LMBP	R290	220-240V~50/60Hz	960/1080	1.3/1.4
NXH260NG	LMBP	R290	220-240V~50/60Hz	1120/1300	1.3/1.4
NXH280NG	LMBP	R290	220-240V~50/60Hz	1220/1390	1.3/1.4
MXH210NA	LMBP	R404A	220-240V~50Hz	960	1.3
MXH230NA	LMBP	R404A	220-240V~50Hz	1150	1.3
MXH260LA	LBP	R404A	220-240V~50Hz	1320	1.3



2、R290系列产品 R290 series commercial products

R290 Inverter compressors

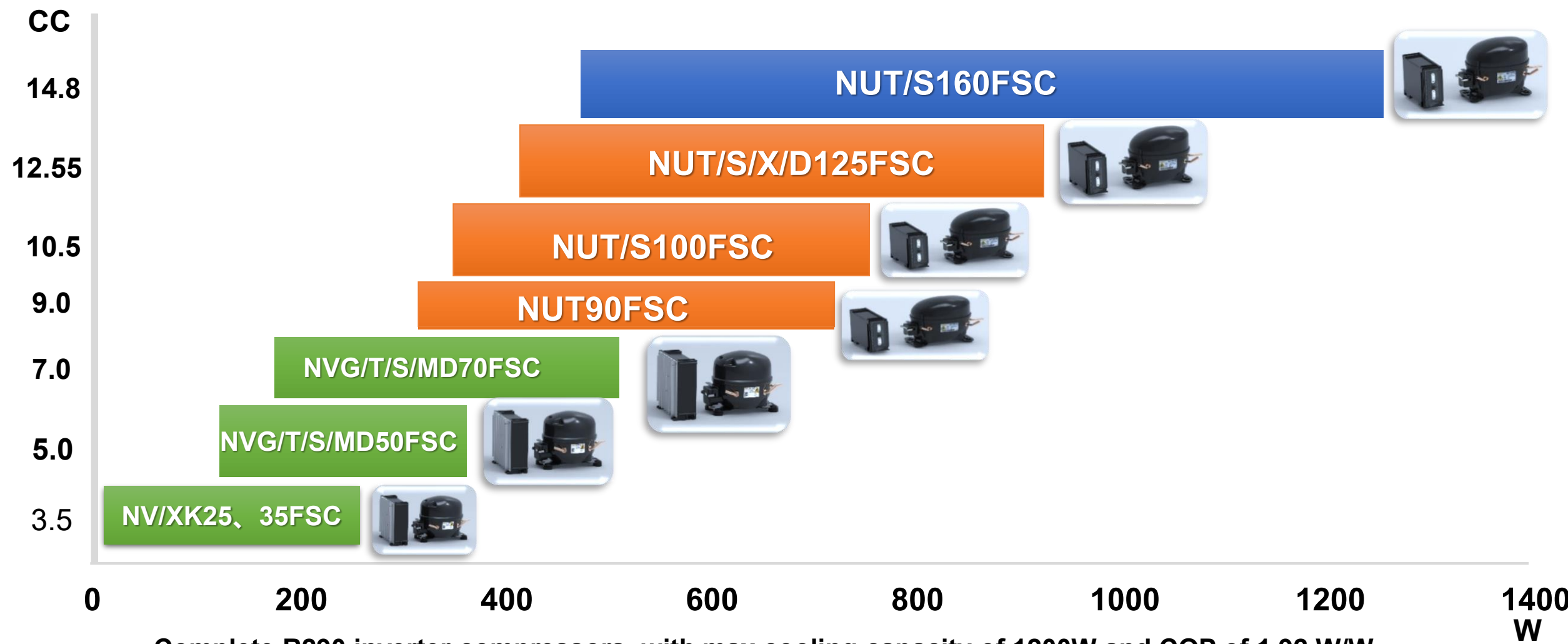

Complete R290 inverter compressors, with max cooling capacity of 1200W and COP of 1.92 W/W.

2、R290系列产品 R290 series commercial products

Vsc application cases



NVS70FSC/NMD70FSC

Coca- cola
cooler



3、R290系列产品与应用 R290 Products and Applications

Vsc application cases



NUT125FSC

900L Chest Freezer

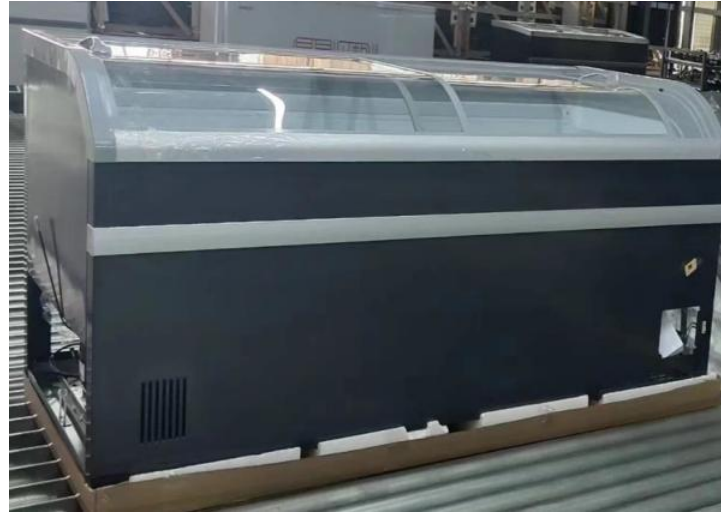

NVT70FSC

700L Chest Freezer



NVG50FSC

BD-519 Chest Freezer

3、R290系列产品与应用 R290 Products and Applications

Commercial R290 variable speed compressor lineup

型号model	气缸容积 Displacement (cm ³)	冷却方式 Cooling	电机类型Motor type	频率 (转速) Hz(speed) (rpm)	制冷量(w) cooling capacity	COP (W/W)	电机描述 Motor	高度Height (mm)
NMS35FSC	3.5	LMBP	F	1600	80	1.70	PMSM	134
				2400	125	1.80		
				3000	155	1.79		
				4500	230	1.60		
NMS50FSC	5.0	LMBP	F	1600	125	1.70	PMSM	134
				2400	195	1.80		
				3000	245	1.79		
				4500	360	1.60		
NMD50FSC	5.0	LMBP	F	1600	130	1.83	PMSM	134
				2400	205	1.92		
				3000	260	1.85		
				4500	370	1.70		
NMS60FSC	6.0	LMBP	F	1600	145	1.70	PMSM	134
				2400	225	1.80		
				3000	285	1.75		
				4500	425	1.65		
NMS70FSC	7.0	LMBP	F	1600	185	1.70	PMSM	134
				2400	285	1.80		
				3000	355	1.79		
				4500	515	1.65		
NMD70FSC	7.0	LMBP	F	1600	190	1.83	PMSM	134
				2400	290	1.90		
				3000	360	1.85		
				4500	520	1.60		

3、R290系列产品与应用 R290 Products and Applications

Commercial R290 variable speed compressor lineup

型号model	气缸容积Displacement (cm ³)	冷却方式Cooling	电机类型Motor type	频率 (转速) Hz(speed) (rpm)	制冷量(w) cooling capacity	COP (W/W)	电机描述Motor	高度Height (mm)
NUS100FSC1	10.0	LBP	F	1800	310	1.70	PMSM	201
				2400	430	1.75		
				3000	550	1.74		
				4500	770	1.55		
NUD100FSC	10.5	LMBP	F	1800	320	1.82	PMSM	201
				2400	430	1.90		
				3000	550	1.85		
				4500	845	1.65		
NUE100FSC	10.5	LMBP	F	1800	290	1.88	PMSM	201
				2400	380	1.93		
				3000	500	1.88		
				4500	760	1.65		
NUS125FSC1	12.5	LBP	F	1800	380	1.70	PMSM	201
				2400	530	1.75		
				3000	635	1.70		
				4500	940	1.47		
NUD125FSC	12.5	LMBP	F	1800	390	1.80	PMSM	201
				2000	415	1.85		
				2400	535	1.85		
				3000	635	1.83		
				4500	950	1.60		
NUS160FSC	15.0	LMBP	F	1800	450	1.65	PMSM	201
				3000	765	1.70		
				5000	1150	1.55		

长虹华意压缩机股份有限公司
CHANGHONG HUAYI COMPRESSOR CO.,LTD

THANK YOU
End of presentation

真诚期待与您的合作!
Sincerely looking forward to your cooperation!

中国·景德镇
JINGDEZHENG · CHINA